



Electrolux

# INDUSTRIAL HEATING EQUIPMENT CATALOGUE





Electric fan heaters .....	4
Gas fan heaters.....	12
Electric infrared heaters.....	16
Air curtains.....	26
Gas infrared heaters .....	36

# ELECTRIC FAN HEATERS

## Fast heating in any conditions

Electrolux electric fan heaters are industrial fan heaters designed for general and direct heating of premises, as well as for drying of surfaces.

The fan heaters in round casing are more often used in construction and finishing works, in rectangular casing - they are better suited for general heating.

State-of-the-art components and a robust design guarantee long-term trouble-free operation. A wide and varied range of models allows you to choose the models that best suit your needs.



Model range	Rated power, max. (kW)						
	2	3	5	9	15	20	30
Electric fan heaters EIFH/G EEC		•	•	•	•	•	•
Electric fan heaters EIFH/DC EEC	•	•					
Ceramic electric fan heaters EIFH/C EEC	•	•					



## Advantages



### Electronic safety thermostat with auto-off lock

Allows automatic start of the fan heater after an emergency shutdown in case of overheating.



### Reliable stainless steel heating elements

Reliable and durable heating elements for operation in complex environments (dust, dirt).



### Housing anti-corrosion treatment and structural elements

Absolutely all Electrolux fan heaters undergo it for protecting them against corrosion even in case of scratches.



### High-precision capillary thermostat

Made of stainless steel, it allows you to precisely maintain the set temperature in the room.



### High ingress protection class

Robust cast metal housing protects from dust, dirt and splashes. Presented in the EIFH/G series.



### Internal thermal screen

Reduces the temperature on the housing surface, provides greater mechanical strength and reliability of the fan heater body.

## ELECTRIC FAN HEATERS

# EIFH/G EEC

The EIFH/G EEC series is a new generation of professional fan heaters in a rectangular case, designed for heavy-duty use. These professional fan heaters have the IP24 class of dust and moisture protection, operate at temperatures up to -30°C and in 24/7 mode without interruptions. The new transformer feet provides increased "ground clearance" in the main position so that the fan heaters can be placed on construction debris, in mud, or even small puddles. The body of the fan heater can be tilted up in the second position. Also, the support acts as an overall power frame, which protects the fan heaters during storage and transportation.



EIFH/G-15 EEC  
EIFH/G-20 EEC  
EIFH/G-30 EEC



EIFH/G-3 EEC  
EIFH/G-5 EEC



EIFH/G-9 EEC

## Technical characteristics

Characteristic/Model		EIFH/G-3 EEC	EIFH/G-5 EEC	EIFH/G-9 EEC	EIFH/G-15 EEC	EIFH/G-20 EEC	EIFH/G-30 EEC
Heating power, up to	kW	3 / 1,5 / 0	4,5 / 3 / 0	9 / 4,5 / 0	15 / 7,5 / 0	20 / 10 / 0	30 / 15 / 0
Capacity	m <sup>3</sup> /h	300	400	850	1700	1700	2400
Supply voltage	V	230		400			
Rated current	A	13,2	19,8	13,2	22,3	30	44,5
Air temperature increase	°C	30	34	32	27	35	37
Appliance dimensions (WxHxD)	mm	280×400×255		305×500×330	409×585×336		409×626×460
Package dimensions(WxHxD)	mm	305×415×280		365×515×310	435×595×345		430×640×475
Net / gross weight	kg	4 / 4,6	4,6 / 5,1	8,2 / 8,8	13 / 13,5	14,5 / 15	20 / 20,9

Electronic automatical thermostat for additional safety and capillary thermostat for precise temperature maintenance

Electric fan heaters

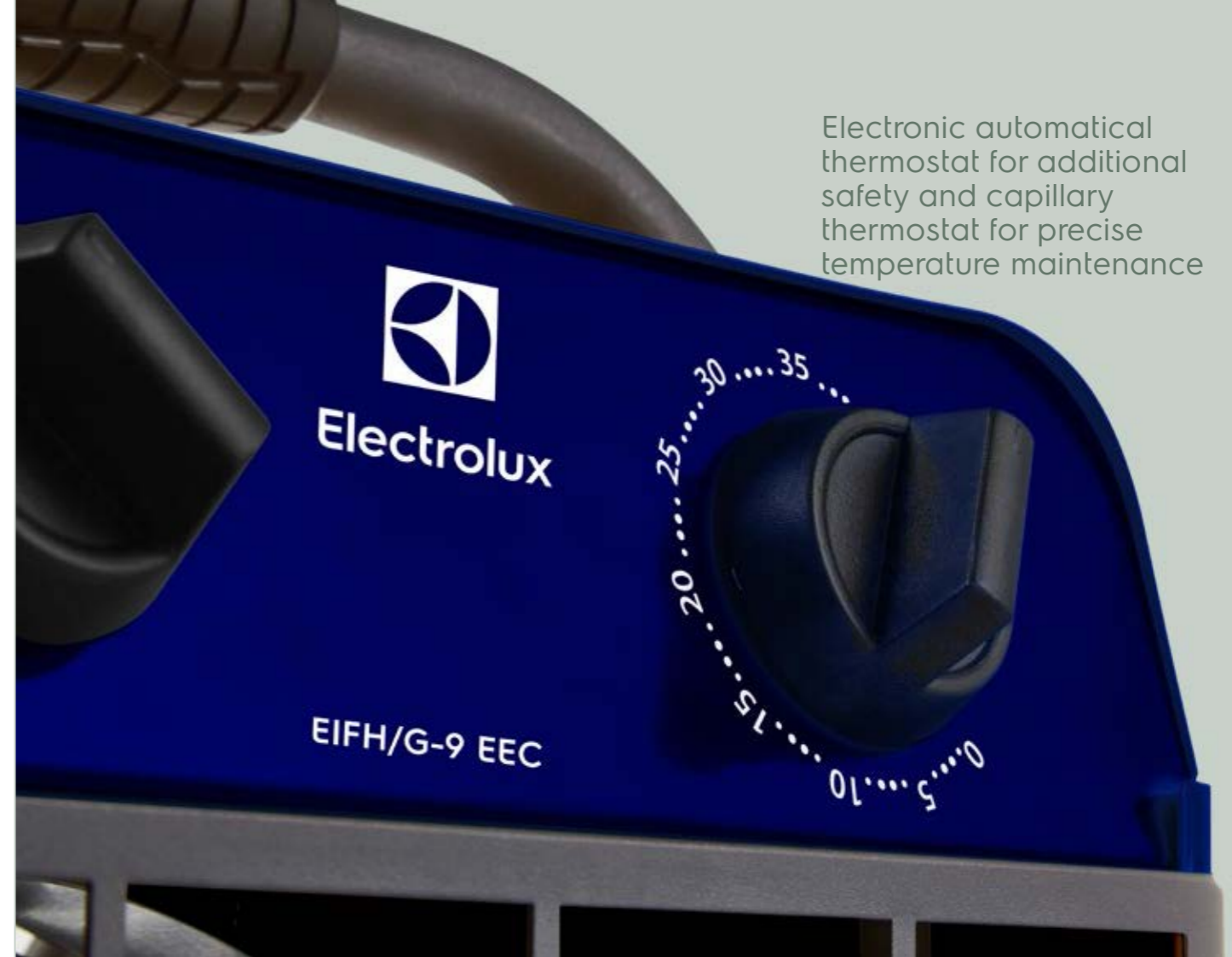

Industrial ingress protected fan

Three-phase plug on the housing for quick connection

## ELECTRIC FAN HEATERS

# EIFH/DC EEC

EIFH/DC EEC series is compact and lightweight directional fan heaters in a round housing. Models are equipped with a modern system of protection against overheating, and the absence of welded joints eliminates the appearance of premature corrosion. The universal grip handle allows you to carry the fan heater conveniently. The heating elements are made of stainless steel. The metal elements of the housing are subjected to special chemical treatment before painting, which helps to prevent corrosion even if the paintwork is damaged.



### Technical characteristics

Characteristic/Model		EIFH/DC-2 EEC	EIFH/DC-3 EEC
Heating power, up to	kW	2/1	3/1,5
Capacity	m <sup>3</sup> /h	260	
Supply voltage	V	230	
Rated current	A	8,9	13,2
Air temperature increase	°C	23	34,5
Appliance dimensions (WxHxD)	mm	245x315x245	
Package dimensions(WxHxD)	mm	260x340x260	
Net / gross weight	kg	2,7/3	3/3,3



Convenient control unit with built-in carrying handle



## CERAMIC ELECTRIC FAN HEATERS

# EIFH/C EEC

Fan heaters EIFH/C EEC are professional fan heaters in ultra-compact, shock-resistant metal housing. They are well suited for local heating and temperature maintenance in small rooms. Thanks to their small size, the fan heater is easy to carry and store. The appliances are equipped with a durable metal-ceramic A class heating element which eliminates the possibility of overheating and saves energy, and the internal thermoregulator maintains the desired heating temperature.



### Technical characteristics

Characteristic/Model		EIFH/C-2 EEC	EIFH/C-3 EEC
Heating power, up to	kW	2,2	3
Capacity	m <sup>3</sup> /h	100	150
Supply voltage	V	230	
Rated current	A	9,6	13,6
Air temperature increase	°C	70	
Appliance dimensions (WxHxD)	mm	150 × 180 × 170	175 × 205 × 180
Package dimensions(WxHxD)	mm	160 × 150 × 180	195 × 175 × 185
Net / gross weight	kg	1,1 / 1,2	1,6 / 1,7



Electric fan heaters

Ultra-compact housing

Energy efficient heating element

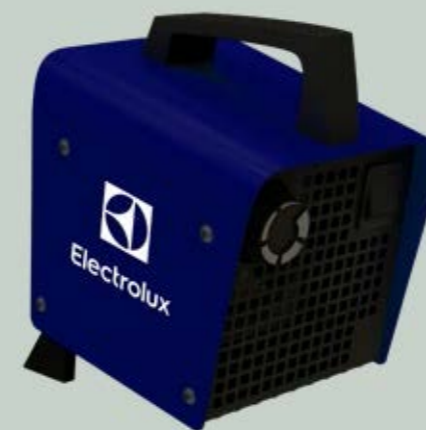

Metal-ceramic heating element has the automatic thermal regulation feature. The higher their temperature, the higher their electrical resistance, the lower their power consumption and the lower their heating. This eliminates overheating and ensures high energy efficiency.

Airflow does not raise dust



Increased heating power

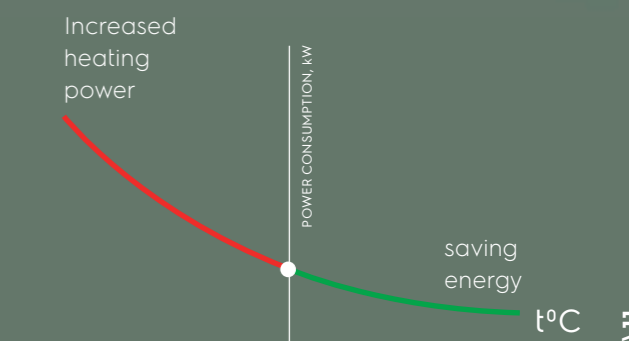

# GAS FAN HEATERS

## Cost-effective solution for local heating in a wide range of operating conditions

Gas fan heaters are powerful professional heat generators running on liquefied gas. These appliances are virtually insensitive to sudden temperature fluctuations and easily transferable.

The metal housing of the Electrolux gas fan heaters has heat reflective functions and is well protected with a corrosion protection coating. Thanks to the installed multi-level protection system, the fan heater switches off when the fuel reserves are out and closes the gas supply in case of flame extinction or overheating. Electrolux gas fan heaters are compact and reliable and have about 100% efficiency.



Model range	Rated power, max. (kW)		
	10	17	33
Gas fan heaters EIFH/L-10 EEC	•		
Gas fan heaters EIFH/L-20 EEC		•	
Gas fan heaters EIFH/L-40 EEC			•

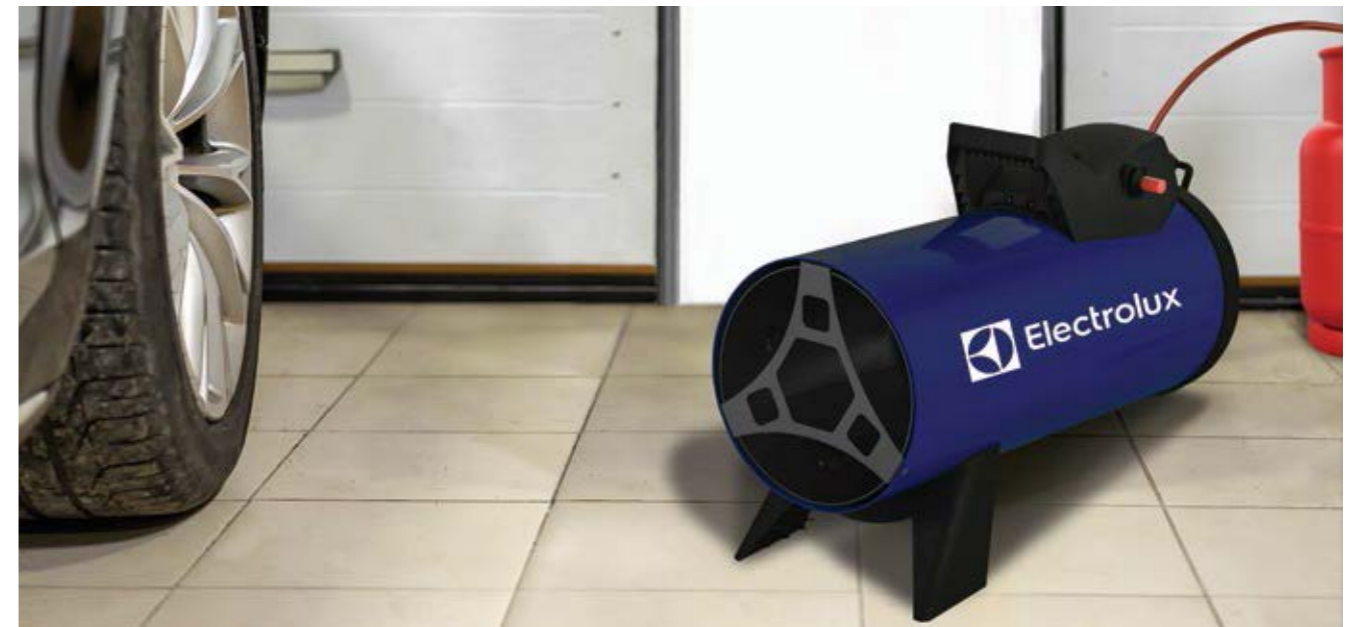

## Advantages



### High air capacity

Powerful electric motors provide a fan heater performance from 270 m<sup>3</sup>/h to 2000 m<sup>3</sup>/h by air.



### High efficiency

Thanks to the low power consumption (from 32 W) and optimal design, the efficiency of Electrolux gas fan heaters is close to 100%.



### Flexible control

Smooth power adjustment allows you to conveniently control the fuel supply to achieve the desired operating mode.



### High safety level

Electrolux gas fan heaters are completely safe thanks to the three-level protection system:

- overheating protection,
- gas leakage protection,
- gas extinction protection.



### Unique design

The burner was developed jointly with the Russian Academy of Sciences, the Institute of Mechanics named after M. T. Kalashnikov.



### The ultra-compact dimensions

The ultra-compact dimensions and light weight make the EIFH/L EEC fan heaters the most mobile in its class.

## GAS FAN HEATERS

# EIFH/L EEC

Professional EIFH/L series gas heat generators are unique development for directed heating of premises and surfaces. The specially developed control unit allows you to carry and start the fan heater with one hand. The ultra-compact dimensions and light weight make the EIFH/L fan heater the most mobile in its class. Thanks to the installed multi-level protection automatics, the fan heater switches off when the fuel reserves are out and closes the gas supply in case of flame extinction or overheating.



EIFH/L-10 EEC  
EIFH/L-20 EEC  
EIFH/L-40 EEC

### Technical characteristics

Characteristic/Model		EIFH/L-10 EEC	EIFH/L-20 EEC	EIFH/L-40 EEC
Heating power, from / to	kW	10	17	10,5 / 33
Gas consumption (min-max)	m <sup>3</sup> /h	0,7 - 0,8	1,3 - 1,45	2,5 - 2,7
Power supply parameters	V	220-240		
Air capacity	A	270		720
Gas pressure	°C	1,5		0,7
Nozzle diameter	mm	0,6	0,85	1,75
Hose connection thread	mm	G1/4"		
Appliance dimensions (WxHxD)	mm	460 × 285 × 186		595 × 360 × 220
Package dimensions(WxHxD)	mm	478 × 270 × 220		615 × 310 × 245
Net / gross weight	kg	5 / 5,7		8 / 9

Convenient handle is integrated into the control unit

Reducer and 2-meter hose included



Unique burner design

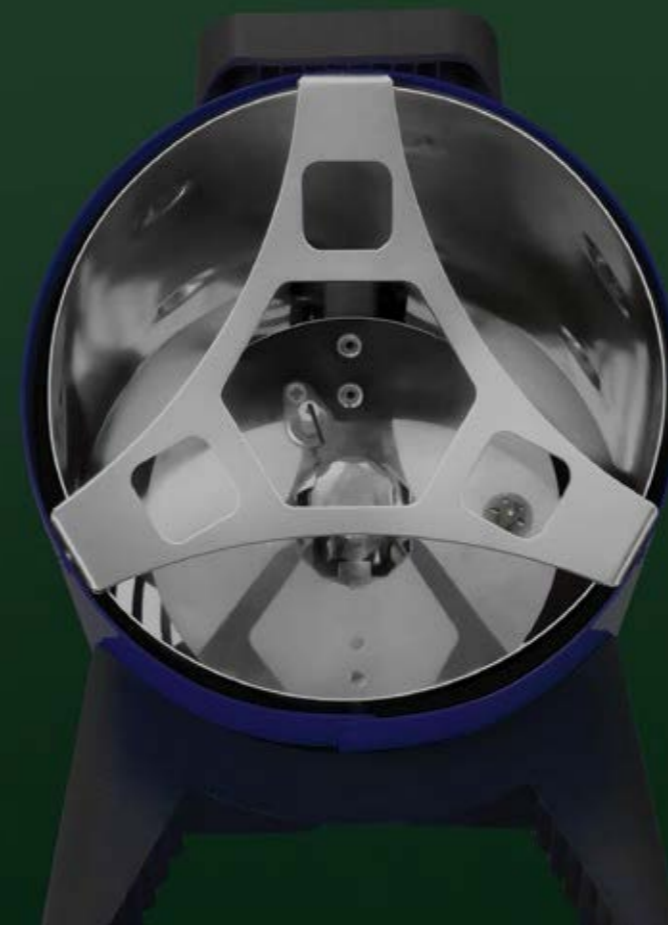



# ELECTRIC INFRARED HEATERS

## Efficient heating in any conditions

Electrolux infrared heaters are a new word in efficient heating systems. Thanks to the infrared principle, the heaters heat objects instead of air, thus achieving high energy efficiency. Electrolux infrared heaters use the latest technology to keep them efficient and consistent throughout their life cycle. A wide range of models allows the best way to solve the any complexity problem. The innovative design of the heaters, using patented solutions, ensures the most efficient heating in all conditions. Certificates of conformity, including international standards, and sanitary-epidemiological conclusions confirm the safety of heaters.



### Model range

	0,6	1	1,5	2,0	3,0
Infrared panel heaters	•	•		•	
Carbon fibre infrared heaters				•	•
Portable quartz infrared heaters			•		

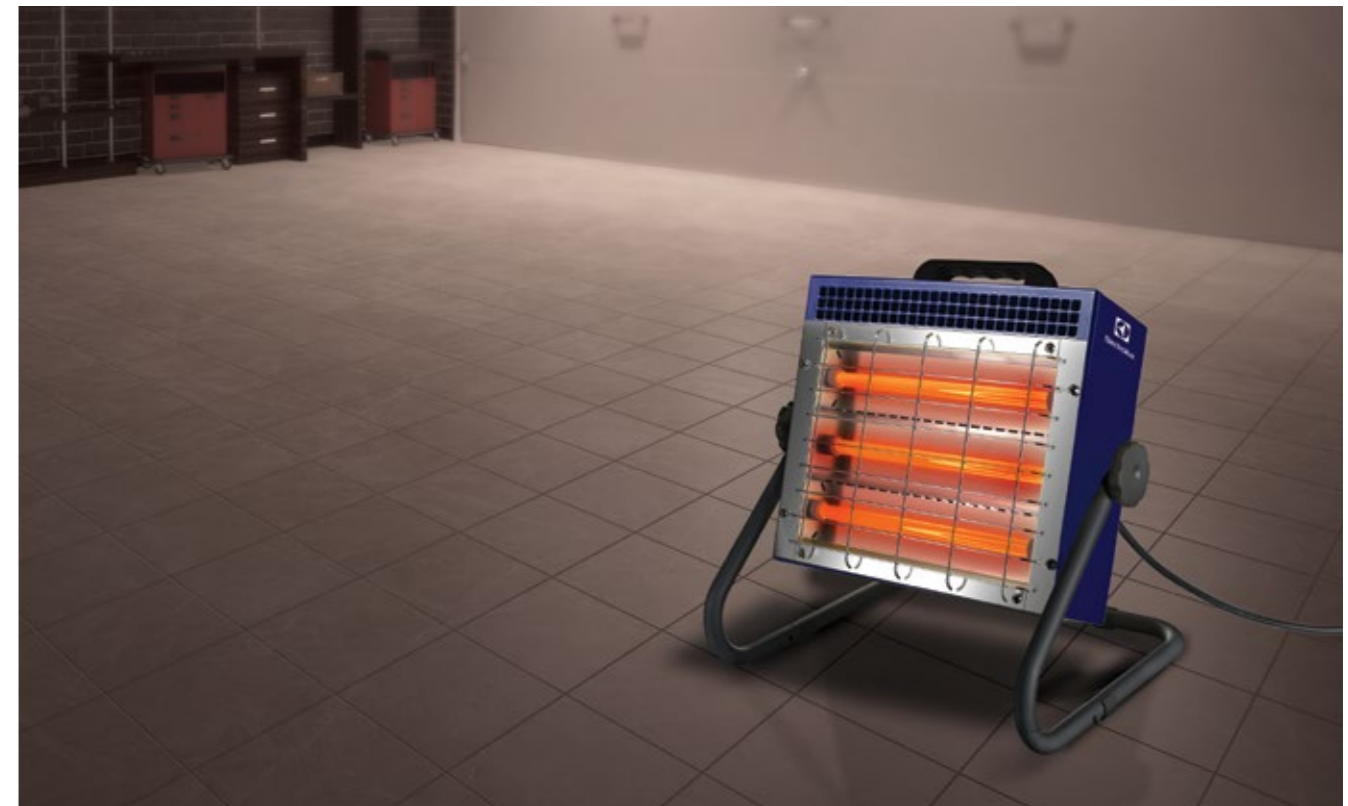

## Advantages



### Patented technologies

The ergonomic trapezoidal body of appliances saves space and makes the heaters almost invisible in the room.



### Multi-purpose

A wide range of infrared heaters allows you to choose the equipment to effectively perform the task of any complexity.



### Uniform heating

Specially shaped reflectors ensure uniform heating within the working area of appliances.



### Reliable protection Stainless steel

The body elements of many heaters are stainless steel, that retains a constant appearance throughout heater service life.

## INFRARED PANEL HEATERS

# EIHC/P EEC

The EIHC/P EEC series for local heating of working areas in rooms with high ceilings or poor heat insulation, where the use of traditional methods of heating is inefficient. Universal swing brackets in the scope of delivery allow for convenient installation and adjustment of the heating angle. The heaters have even more compact body and sides with increased tilt angle, thanks to which the appliance under the ceiling looks much thinner visually. The increased degree ingress protection class IP54 allows to use heaters even outside. The series is represented by models in a silver body, with stainless steel elements, with high-performance panels with black anodizing.



SILVER

BLACK

### Technical characteristics

Characteristic/Model		EIHC/P-600S EEC	EIHC/P-1000S EEC EIHC/P-1000B EEC	EIHC/P-2000S EEC EIHC/P-2000B EEC
Rated power, up to	kW	0,6	1	2
Supply voltage	V	230/50		
Maximal rated current	A	2,6	4,4	8,7
Installation height	m	2,5-3,5		2,5-4,5
Heating area	m <sup>2</sup>	6	10	20
Ingress protection class		IP54		
Appliance dimensions (WxHxD)	mm	820 × 40 × 130	1190 × 40 × 130	1190 × 40 × 255
Package dimensions(WxHxD)	mm	875 × 55 × 150	1250 × 55 × 150	1250 × 55 × 280
Net / gross weight	kg	1,9 / 2,2	2,7 / 3,1	5 / 5,7



Efficient and invisible heating  
in all conditions

Electric infrared heaters

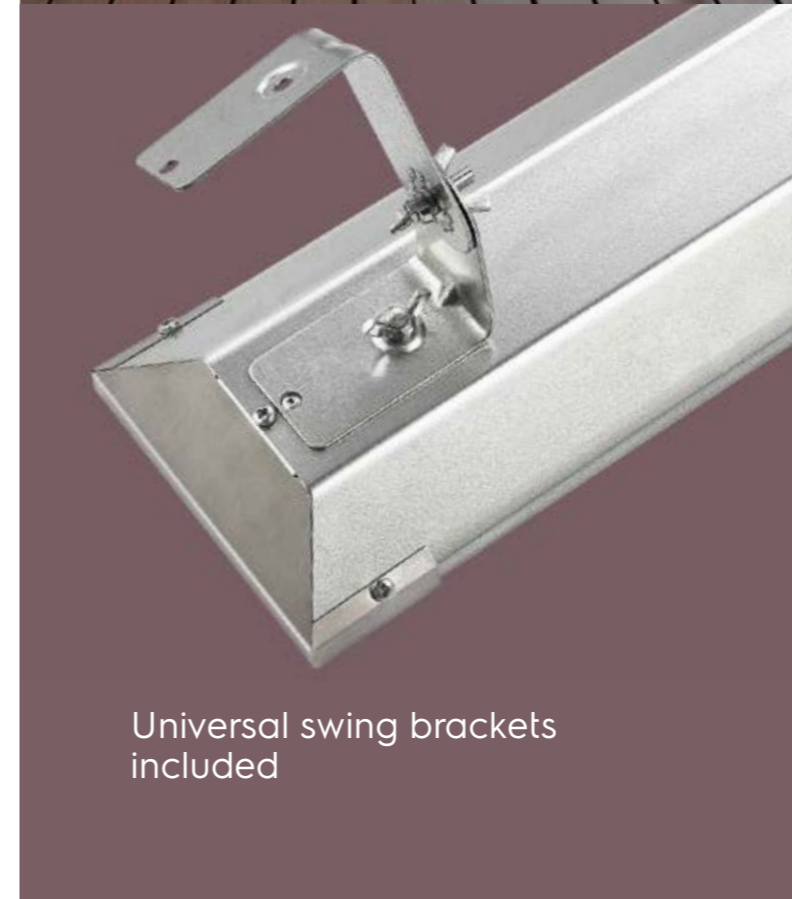

Universal swing brackets  
included

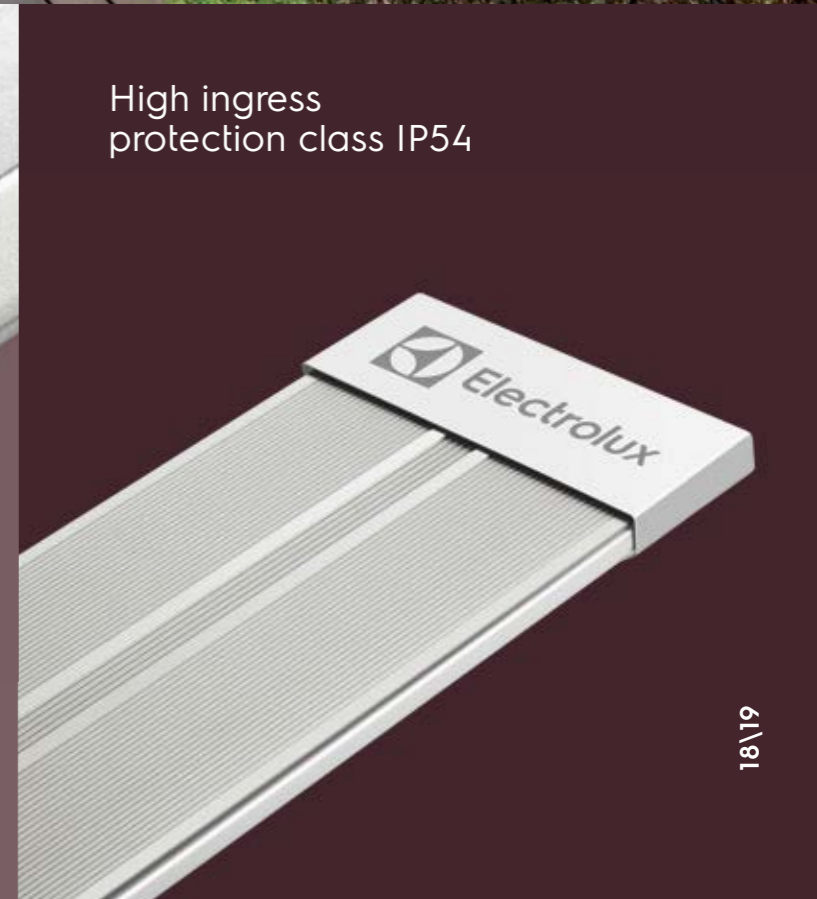

High ingress  
protection class IP54

18/19

## INFRARED LAMP HEATERS

# EIHC/DU EEC

EIHC/DU EEC series infrared heaters are universal type of infrared heaters, which are ideal for heating semi-open spaces and outdoor areas. The increased IP-protection allows them to be used even in the rain. The heater can be mounted on almost any surface using a set of brackets and wing screws for tool-free installation. It is also possible to mount the appliance on a steel telescopic tripod, which allows you to quickly move it. The heater is made in a steel body with a convection cooling system, which prevents its excessive heating, and steel chrome screen protects against accidental contact with the heating element. The appliance is equipped with a specially ribbed reflector, providing distribution of heat flow throughout the heating zone. The heaters have a remote control included.

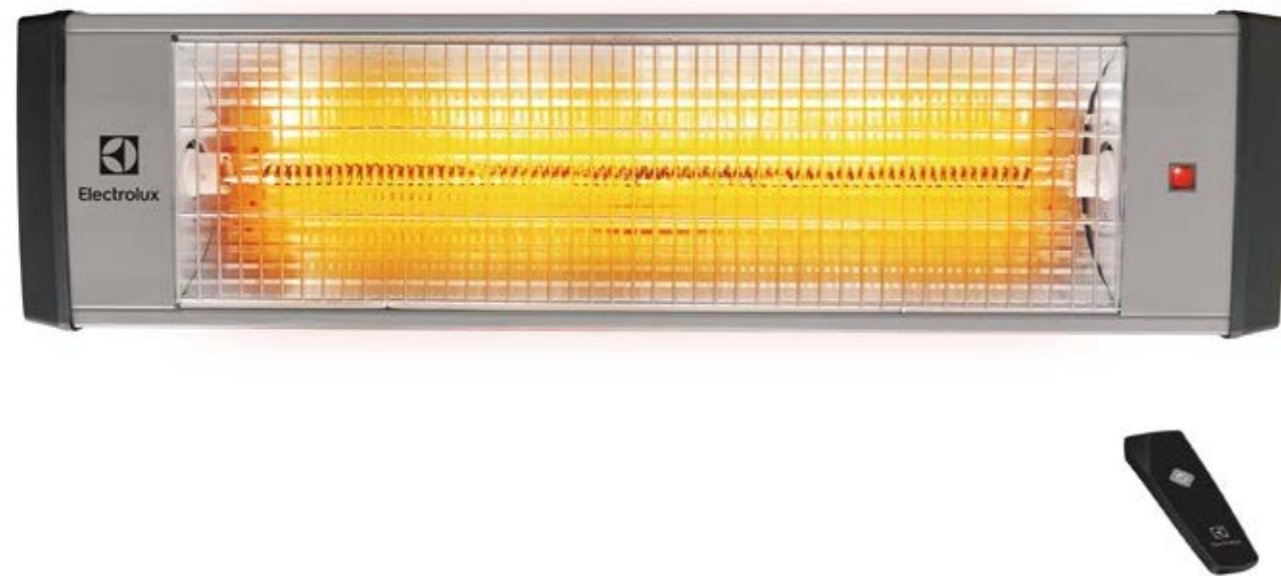

### Technical characteristics

Characteristic/Model		EIHC/DU-2000 EEC
Rated power, up to	kW	2
Supply voltage	V	230
Maximal rated current	A	9,1
Network connection		power cord with a plug
Installation height	m	up to 3,5
Main heating area	m <sup>2</sup>	25
Appliance dimensions (WxHxD)	mm	740 × 90 × 180
Package dimensions(WxHxD)	mm	790 × 130 × 230
Net / gross weight	kg	3,0 / 3,4



Reflector with fins for 100% uniform heating

Integrated thermostat for temperature maintenance



Universal swing brackets included

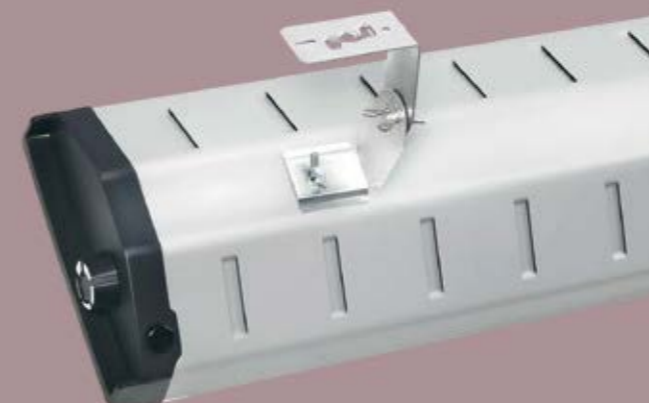

Can be mounted on a professional steel telescopic tripod EIHC/DU Stand EEC

## PORTABLE INFRARED HEATERS

# EIHC/DM EEC

Portable infrared heaters are an effective solution for local heating. There is no need to wait for the entire volume of air and room walls to warm up, it becomes warm right after switching on. Due to the focused effect of infrared rays, the perceived thermal power is approximately 2 times higher than the nominal power. And the possibility of local use allows to save on the heating of unused spaces.

Electrolux infrared heaters are effective even in outdoor areas and in rooms without thermal insulation. They are often used for heating workplaces in workshops, on construction sites, in utility rooms, in small factories, for fast defrosting. They are particularly effective for drying painted or wet surfaces, as they do not raise dust from the floor during operation.



### Technical characteristics

Characteristic/Model		EIHC/DM-1500 EEC
Rated power, up to	kW	1,5 / 1 / 0,5
Supply voltage	V/Hz	230/50
Rated current	A	6,5
Ingress protection class		IP21
Electric protection class		I
Network connection		Euro plug
Heating area	m <sup>2</sup>	25
Appliance dimensions (WxHxD)	mm	360 × 340 × 290
Package dimensions(WxHxD)	mm	340 × 275 × 135
Net / gross weight	kg	2,1 / 2,5

Chrome protective grill

Electric infrared heaters

Efficient quartz infrared lamps

### Combined convective-infrared heating system

Additional heating based on air circulation. Cold air enters the heater from the bottom, heats up in the housing and exits through the exhaust grill, spreading evenly throughout the room.



# ELECTRIC INFRARED HEATERS

## Intelligent control of climate equipment

Electrolux thermostats combine intuitive control and innovative solutions. The product range includes both classic mechanical models and modern ones with a touch screen.



ETT series  
Programming by day of the week



ETA series  
Programming during the day



ETB series  
Mechanical control



Electric thermostats

# AIR CURTAINS

## Heating and energy-saving for commercial space

Electrolux heat air curtains are used to separate climatic zones with different temperatures, by creating a powerful air flow in the area of windows, doors and gates. Usage of Electrolux air curtains allows to significantly reduce the energy loss spent on room heating or air conditioning. With the right selection and installation of curtains provide reduction of heat losses through openings up to 80%, and their payback period often does not exceed one season. In the cold season, the curtains are used for additional heating of the room, and in summer, working in the non-heating mode, allow to keep air conditioning and protect from insects.

### Places of use

#### A series

Goods dropoff windows and outdoor cashboxes. Entrance gates and halls of restaurants, cafes, hotels. Supermarkets and any retail outlets with standard door heights.

#### B and C series

Entrance gates of shopping and business centers, checkpoints of enterprises, loading gates of warehouse and logistics centers, sports facilities and transport infrastructure.

#### Interior series

Shopping, exhibition and business centers with increased requirements for appearance. Checkpoints of enterprises and sports facilities with entrance gates made of glass and metal.



Model range	Installation high, m	Heating type	Width of the curtain, m					
			0.6	0.8	1	1.5	2	2.2
A series	2,2		•	•	•	•		
B series	2,5				•	•		
					•	•		
C series	3,5				•	•	•	
					•	•	•	
					•	•	•	
Interior series	4,0							•

– Electric heating type   
 – Water heating type   
 – Without heating

## Advantages



#### Impellers PUNKER (Germany)

The tangential ventilation wheels with individual balancing ensure high performance and low noise.



#### Universal mounting

The B and C series can be installed horizontally above the opening or vertically to the side of it.



#### Aerodynamic air grid

Aluminum drop-shaped grid focus the airflow in the plane of the aperture providing better protection.



#### Anti-corrosion coating

All body parts of the air curtain are degreased and phosphate before painting, which protects the body against corrosion.



#### Compactability

The height of the air curtain's body A series is only 13 cm, optimal for rooms with a small distance from the door to the ceiling.



#### Full set

Remote control with internal temperature sensor, bracket for mounting and connection wire supply with industrial curtains as a set.

## HEAT AIR CURTAINS

# A SERIES

A series is a new generation of compact low housing curtains for commercial use. Special body shape of the curtains contributes to their low visibility and goes well with any interiors. The only 13 cm body allows to place curtains over the doors with a minimum distance from the ceiling.

A number of technical solutions are used in A series curtains to reduce noise and increase their lifetime.

A wide assortment range with a combination of various characteristics and control methods allows to choose the best solution for protecting any doorways.



## Technical characteristics

Characteristic/Model		EEAC/A-06-3E EEC	EEAC/A-09-3ET EEC	EEAC/A-09-3ER EEC	EEAC/A-10-6ER EEC	EEAC/A-15-9ER EEC
Maximum installation height up to	m	2,2				
Heating power up to	kW	3 / 1,5 / 0	3 / 1,5 / 0	3 / 1,5 / 0	6 / 3 / 0	9 / 6 / 0
Air flow	m <sup>3</sup> /h	350	480	480	750	1050
Power supply voltage	V	230				400
Air temperature increase	°C	26	19	19	24	26
Control		keys on body	keys on body + thermoregulator		Remote control	
Appliance dimensions (WxHxD)	mm	595x135x185	875x135x185	875x135x185	1025x135x185	1505x135x185
Package dimensions (WxHxD)	mm	640x155x210	920x155x210	920x155x210	1070x155x210	1550x155x210
Net weight/Gross weight	kg	3,8/4,2	5,2/5,8	5,2/5,8	7,3/8,0	11/11,7



Top air intake  
reduces noise

Heat air curtains

Stacking nozzles for  
flow focusing



Modern "lightweight"  
body design



Convenient suspension  
on the built-in brackets



28\29

## HEAT AIR CURTAINS

# B and C SERIES

Air curtains of the B and C series are used for protecting commercial facilities from the penetration of cold air and additional heating of the vestibules and loading areas in winter.

The B series is mainly used for protecting standard doors in commercial areas with high traffic.

The C series is used to protect loading and storage gates or for standard doors in regions with cold climates and high wind loads on open openings.

Electrolux air curtains have three types of heating:

1. Electric heating with minimal cost of installation and connection.
2. Water heating with minimal operating costs, the air is heated by passing through a copper-aluminum heat exchanger.
3. Curtains without heating for rooms with limited access to energy carriers.

The package includes universal mounting brackets and remote controls with an electronic thermostat for controlling of the air curtains and room temperature.



### Technical characteristics (electrical heaters)

Characteristic/Model		EEAC/B-10-6ER EEC	EEAC/B-15-9ER EEC	EEAC/C-10-6ER EEC	EEAC/C-15-9ER EEC	EEAC/C-20-12ER EEC
Maximum installation height up to	m	2,5			3,5	
Heating power up to	kW	6 / 4 / 0	9 / 4,5 / 0	6 / 4 / 0	9 / 4,5 / 0	12 / 6 / 0
Air flow	m <sup>3</sup> /h	1100/900/750	1600/1300/1050	1500/1200/1000	2200/1900/1600	3000/2600/2100/
Voltage	V	230/50 - 400/50	400/50	230/50 - 400/50	400/50	400/50
Ingress protection class		IP 21				
Control		Remote control				
Dimensions (WxHxD)	mm	1055x209x261	1500x209x261	1065x258x286	1500x258x286	2000x258x286
Net/Gross weight	kg	14,5/17,5	19,5/24	17,5/21	24/29,5	30,5/37,5

### Technical characteristics (heat exchanger)

Characteristic/Model		EEAC/B-10-8WR EEC	EEAC/B-15-14WR EEC	EEAC/C-10-12WR EEC	EEAC/C-15-20WR EEC	EEAC/C-20-30WR EEC
Maximum installation height up to	m	2,5			3,5	
Heating power (90/70/15) up to	kW	8,3	13,9	12,3	19,9	29,5
Air flow	m <sup>3</sup> /h	1100/950/800	1600/1300/1050	1600/1300/1100	2300/1900/1700	3200/2800/2400
Voltage	V	230/50				
Max water pressure/temperature	°C/Bar	150/16				
Ingress protection class		IP 21				
Control		Remote control				
Dimensions (WxHxD)	mm	1055x209x301	1500x209x301	1065x258x286	1500x258x286	2000x258x286
Net/Gross weight	kg	14,5/17,5	19,5/24	19,0/22,5	27/32,5	33,5/40,5

### Technical characteristics (non-heat)

Characteristic/Model		EEAC/C-10-VR EEC	EEAC/C-15-VR EEC	EEAC/C-20-VR EEC
Maximum installation height up to	m	3,5		
Air flow	m <sup>3</sup> /h	1600/1250/1050	2300/2000/1700	3200/2700/2200
Power consumption	W	170	200	250
Voltage	V	230/50		
Ingress protection class		IP21		
Control		Remote control		
Dimensions (WxHxD)	mm	1065x258x286	1500x258x286	2000x258x286
Net/Gross weight	kg	15/18,5	21/26,5	26,5/33,5

External rotary engines  
with increased life time

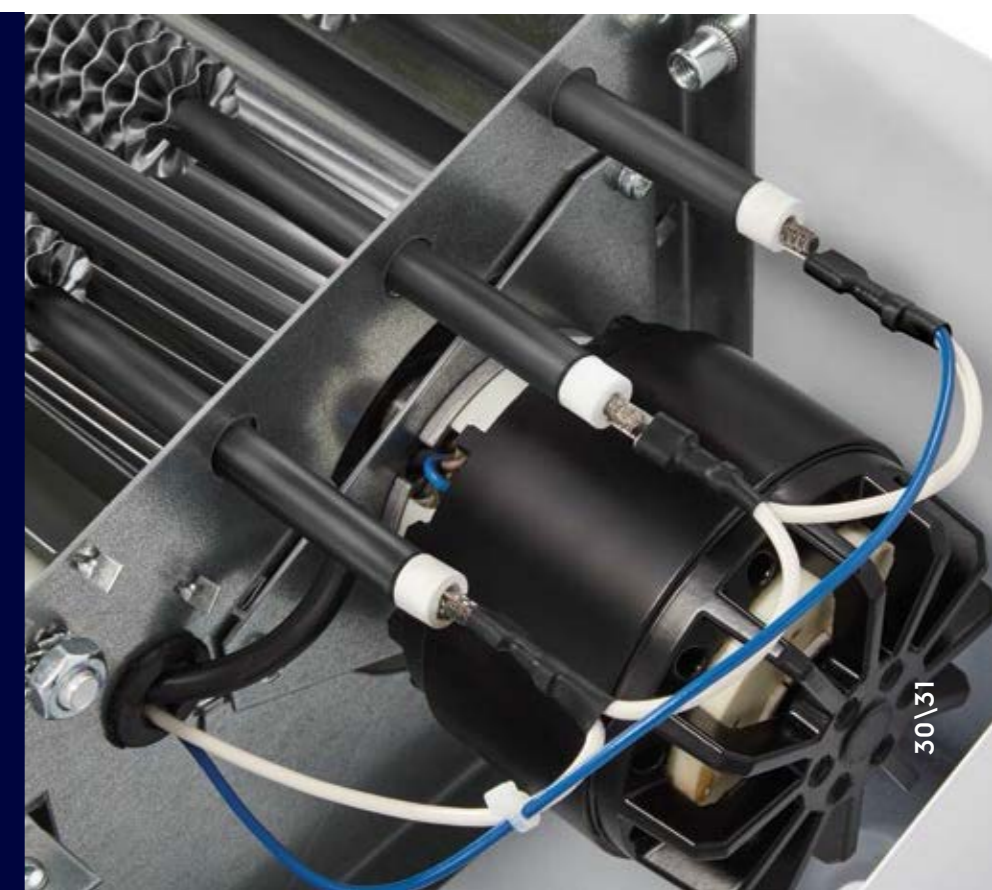



## INTERIOR HEAT AIR CURTAINS

# EEAC/IV EEC

Interior EEAC/IV EEC curtains series are an effective solution for gates protection in commercial premises with increased requirements for the equipment appearance. Full-size side panels without perforation block noise spreading, providing increased comfort. Special design of the nozzle with twin air flow guides generates a dense uniform air flow along the entire length of the curtain without dead zones.

The curtains are versatile, for floor installation on the left/right relative to the opening or horizontal installation above the doorway. Connection to power network and hot water can be performed in a hidden scheme, through the basement, or the curtain's upper side.



Full-size nozzle without "dead zones"

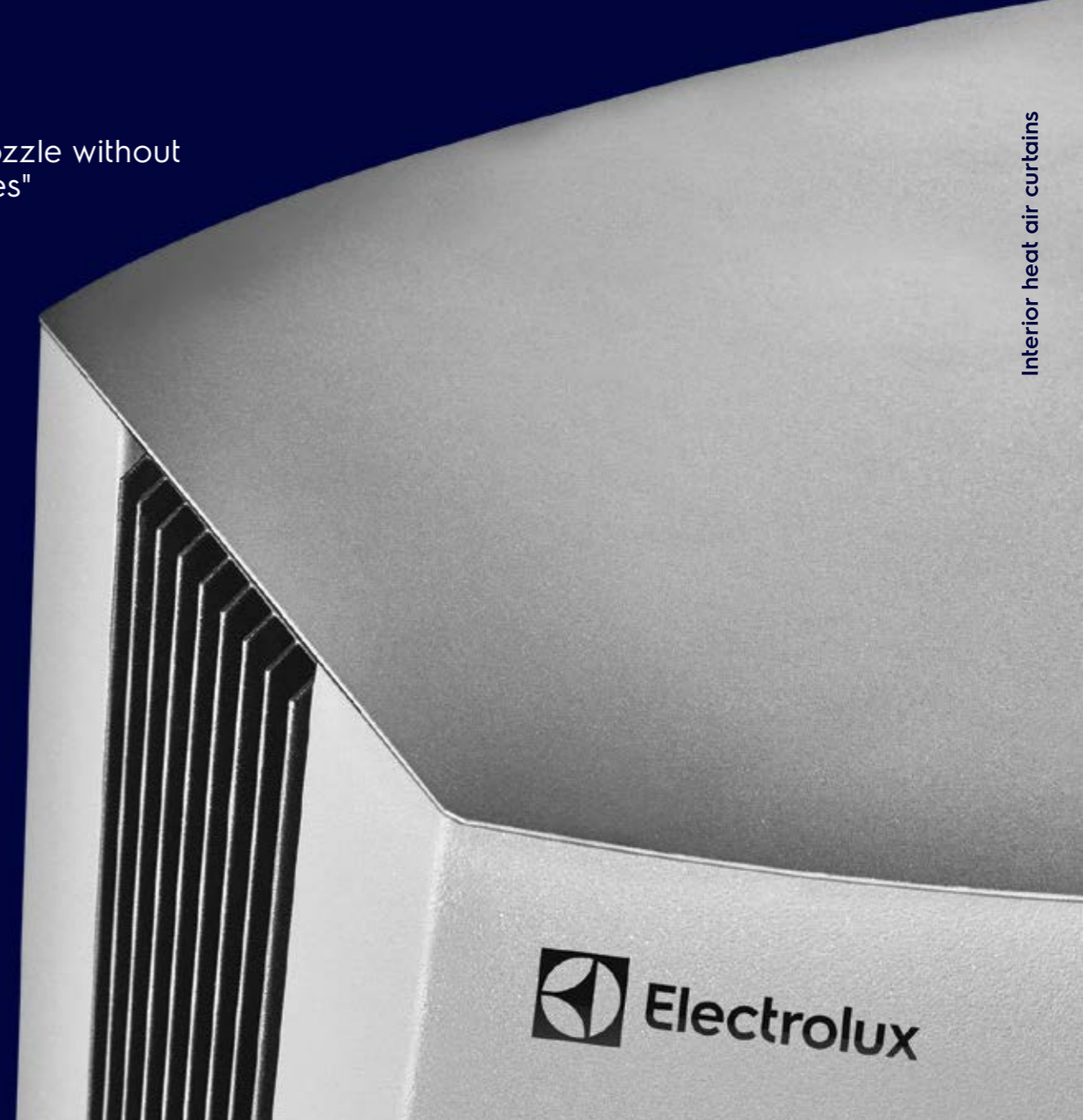

Interior heat air curtains

## Technical characteristics

Characteristic/Model		EEAC/IV-22-18ER EEC	EEAC/IV-22-35WR EEC
Maximum range of air jet length is up to	m	4	4
Heating type		Heating element	Water heat exchanger
Airflow	m <sup>3</sup> /h	5300 / 4000	5000 / 3500 / 2800
Heating power up to*	kW	18 / 9 / 0	35,1
Power consumption of engines, kW	W	460	420
Power supply voltage	V	400	230
Mains cable	mm <sup>2</sup>	5x4,0	3x1,0
Control		Wire control	
Ingress protection class		IP21	IP21
Appliance dimensions (WxHxD)	mm	500 × 2210 × 360	500 × 2210 × 360
Package dimensions (WxHxD)	mm	2330 × 800 × 560	2330 × 800 × 560
Net weight/Gross weight	kg	86 / 134	90 / 138

Reliable external rotary engines

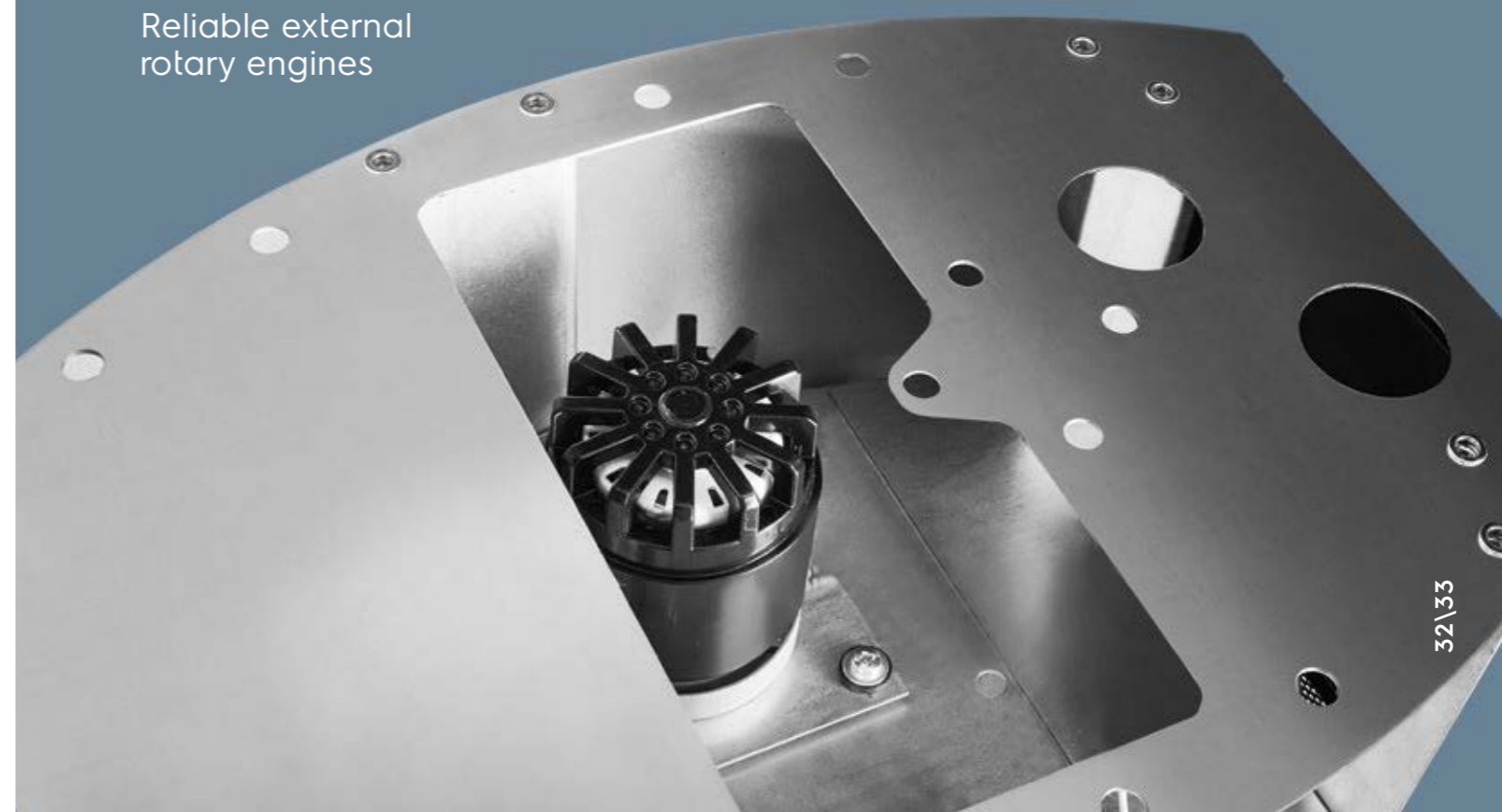

32/33

## WATER FAN HEATER FOR COMMERCIAL PREMISES

# EIFH/W EEC

Compact water fan heaters of EIFH/W EEC series are perfect for heating of small and medium-sized premises, for example, shops, utility and production premises, workshops and warehouses. The heater's body is made of modern durable material - foamed polypropylene, which in addition to effective noise reduction, provides high mechanical strength, resistance to environmental influences and chemical pollution. It is enough to unscrew only four bolts to fully access the heat exchanger to clean it. Energy-efficient fan with three operating modes allows to reduce the costs on additional equipment.



### Technical characteristics

Characteristic/Model		EIFH/W-15 EEC	EIFH/W-25 EEC
Rated heating power up to *	kW	10,3	19,7
Maximum heating power up to **	kW	18,3	32,3
Number of heat exchanger		1	2
Air flow	m <sup>3</sup> /h	2800/2200/1700	2400/2000/1500
Max. working temp. water/max. operating pressure	°C/MPa		150/1,6
Max. air steam range	m		12
Power supply	V		230
Max. engine power/Rated current in the maximum ventilation mode	W/A		100 / 0,45
Ingress protection class/Electrical protection class			IP54 / I class
Noise level ***	dB(a)		44
Appliance dimensions (WxHxD)	mm		640x585x300
Package dimensions (WxHxD)	mm		600x680x400
Net weight/Gross weight	kg	11 / 15	12,9 / 16,9

\* - At maximum efficiency and coolant temperature of 90/70, air temperature at the unit's inlet is 15 °C

\*\* - At maximum efficiency and coolant temperature of 130/90, air temperature at the unit's inlet is 0 °C

\*\*\* - Noise level on 5 m distance from the unit



Noise reduction material housing

Three operating modes of the fan

Water fan heaters

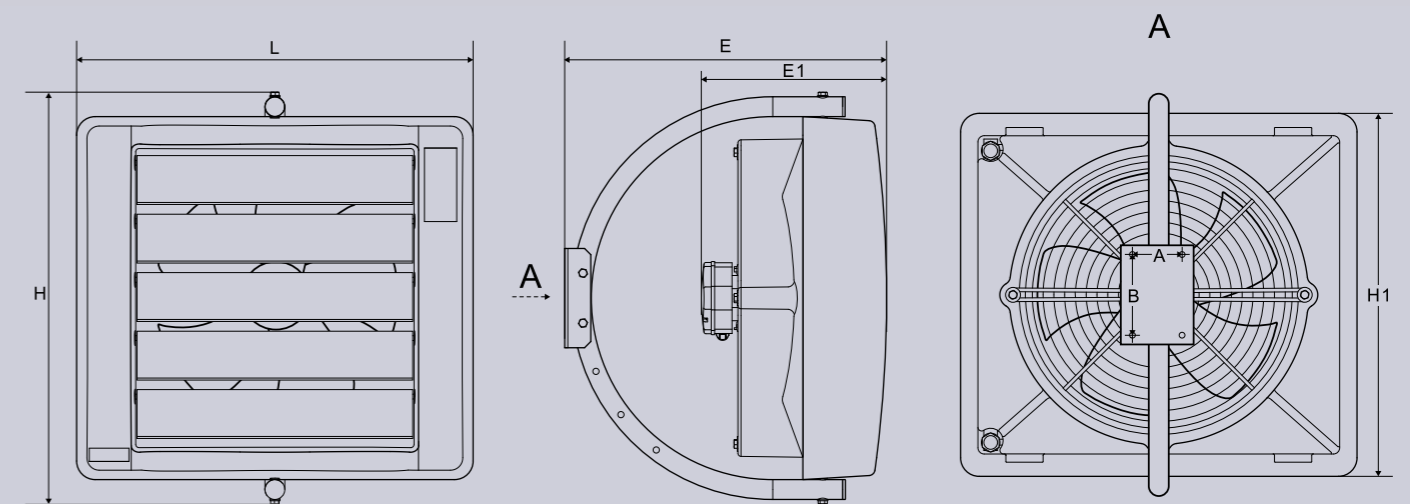

Model	L, mm	H, mm	H1, mm	E, mm	E1, mm	A, mm	B, mm
EIFH/W-15 EEC	585	665	640	520	300	80	130
EIFH/W-25 EEC							

# GAS INFRARED HEATERS

## Efficient heating at home and outdoors all year round

Electrolux gas infrared heaters are used for efficient and economical infrared heating indoors and outdoors. The multi-level protection system on all models of gas infrared heaters ensures reliable and safe operation throughout the entire lifetime. Devices are very economical, mobile and independent of power supply, what makes them to be universal source of heat in all conditions.



### Model range

Heating power, up to (kW)

Gas infrared heaters  
EIHC/O-13 EEC

13

•

Gas infrared heaters  
EIHC/O-13E EEC

•



## Advantages



### Independence from electricity

Gas powered heaters provide complete independence from electricity. Gas heat is much more economical and convenient to use.



### High quality ceramic panel

The side panels and products body are made of high-quality steel for maximum protection against corrosion.



### Remote controller

Remote control provides fast and convenient switching on/off, as well as heater power level adjustment.



### Control flexibility

Smooth power adjustment allows convenient control of fuel supply to achieve the desired operating mode.



### Reliable protection

Heaters are equipped with a protective thermocouple, tip-over sensor and solenoid valve.



### 100% efficiency

All energy consumed by the device is converted into heat.

## GAS INFRARED HEATERS

# EIHC/O EEC

EIHC/O EEC combines the powerful effective heating and equalized heat distribution. Stainless steel case AISI 430 with the special anti-corrosive treatment, higher thermal efficiency, uniform illumination and warm of Japanese bowl.

Thermal infrared effect is created using the pillars of fire, which are enclosed in the glass bottle. In the evening the fire makes the incredible performance – it is not only warmly, but also brightly close to EIHC/O EEC.

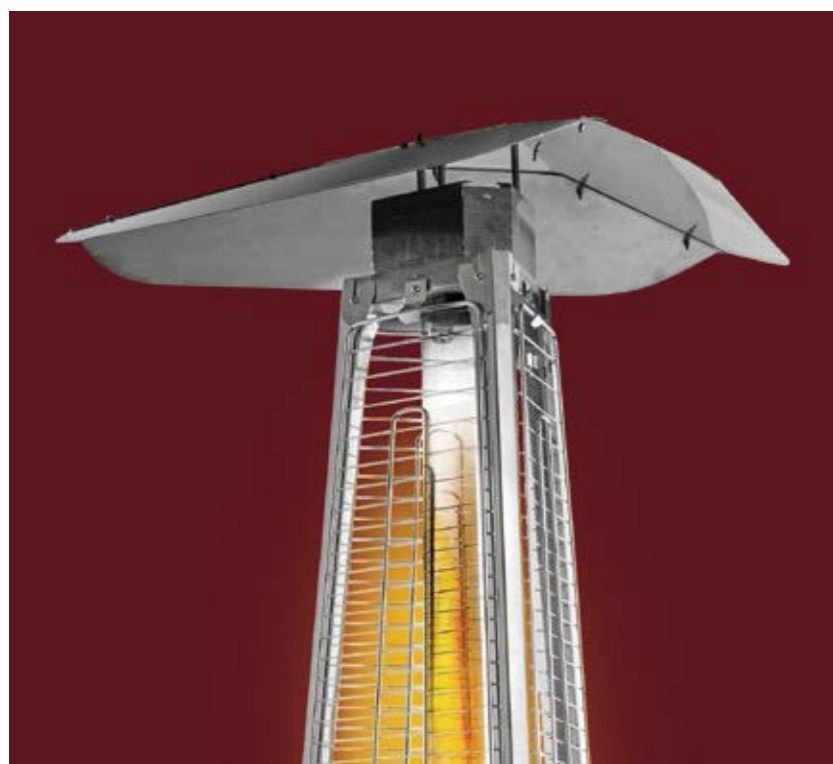

## Technical characteristics

Characteristic/Model		EIHC/O-13 EEC	EIHC/O-13E EEC
Heating power, up to	kW	13	
Rated gas consumption	kg/h	0,3 - 0,97	
Control		Mechanical power regulator	Push-button power controller + remote control
Fuel type		propane, propane-butane	
Heating area	m <sup>2</sup>	up to 25	
Ignition method		electro piezo ignition	automatic electro piezo ignition
Appliance dimensions (WxHxD)	mm	847 × 2410 × 770	
Package dimensions (WxHxD)	mm	1450 × 560 × 560	
Net weight/Gross weight	kg	40 / 45	

The best heating efficiency outdoors in the class of "Outdoor gas infrared heaters"

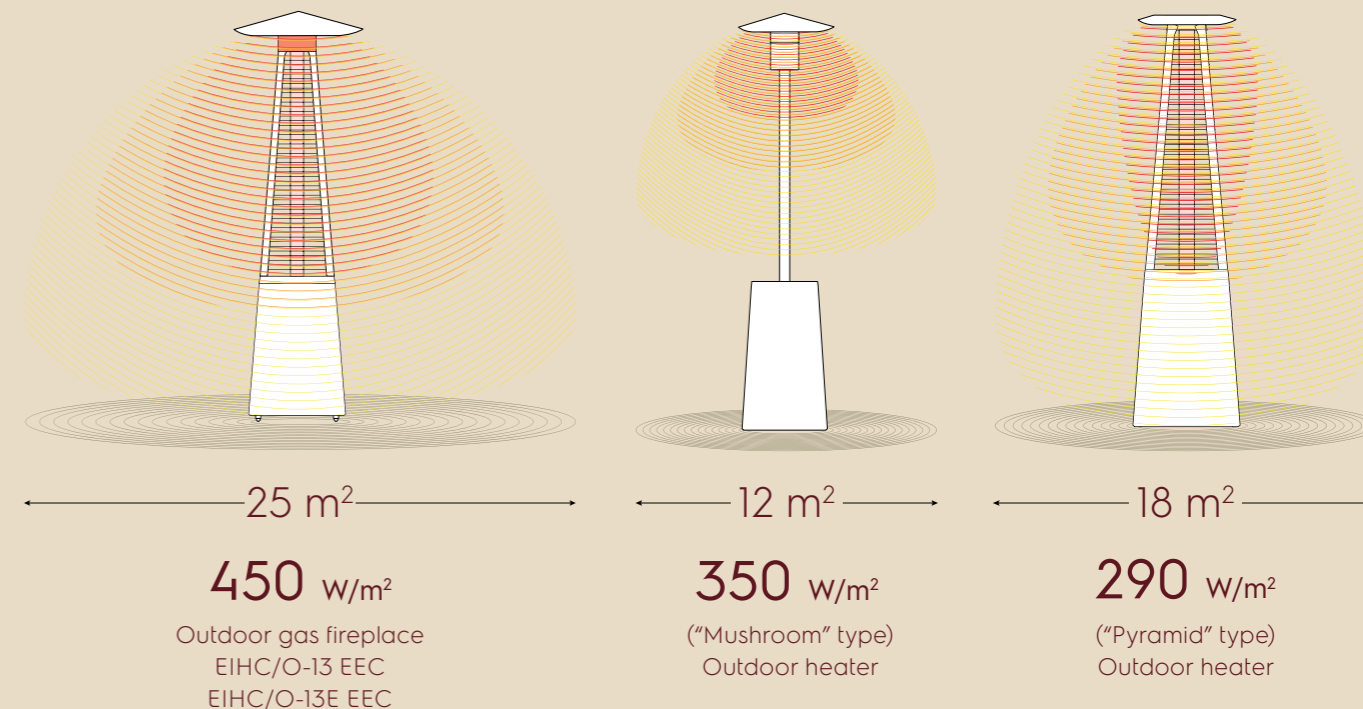

The key indicator characterizing efficiency of an outdoor IR heater is the heat flux density (W/m<sup>2</sup>). It shows how much heat volume the device could give out over a certain area \*.



Auto shutdown when falling



Remote control included  
(for model EIHC/O-13E EEC)



Unique afterburner

\* Data provided on the basis of thermal imaging under the conditions: distance from the device 1.5 m, air temperature +15 °C.

Learn more on our website  
[www.home-comfort.com](http://www.home-comfort.com)

Mistakes and typing errors may be permitted in texts and numeric notations. Product design and technical data may vary from the one pictured in the catalogue.

Electrolux is a registered trademark used under license from AB Electrolux (publ).

Version CIHE 2022/1

